

5759337COM Nightstand

Ameriwood
HOME

Date of Purchase ___ / ___ / ___
Lot Number:

B345759337COM2

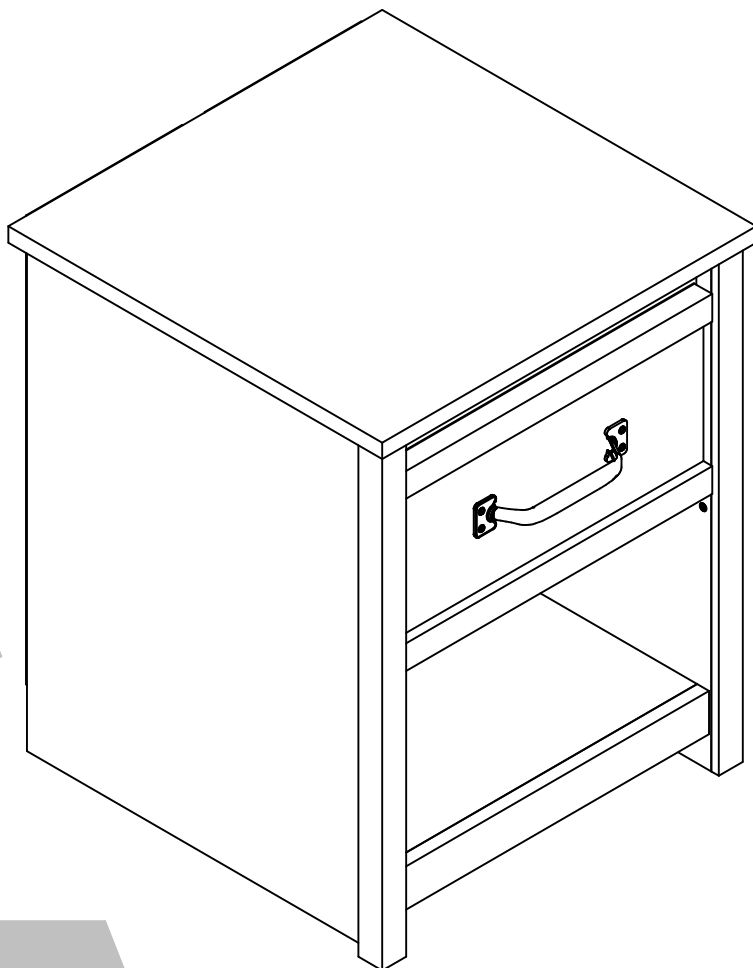

THIS INSTRUCTION BOOKLET CONTAINS **IMPORTANT** SAFETY INFORMATION. PLEASE READ AND KEEP FOR FUTURE REFERENCE.

Do Not Return This Product!

Contact our customer service team for help first.

Call: 1-800-489-3351 (toll free)

Monday-Friday 9am - 5pm CST

Visit: www.ameriwoodhome.com



WARNING

- Unit can tip over causing severe injury or death.
- Anchor unit to stud in wall (if instructed to).
- Do Not allow children to climb on unit.
- Put heavy items on lower shelves or drawers.

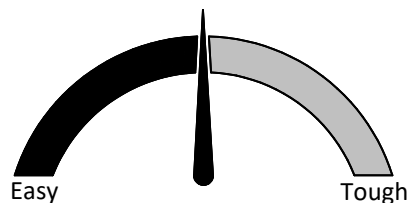

Assembly Difficulty Meter

Follow Ameriwood Home



Contact Us!

Do NOT return this product!

Contact our friendly customer service team first for help.

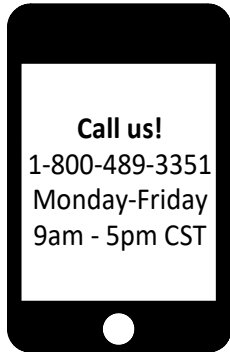

Visit ameriwoodhome.com to view the limited warranty valid in the U.S. and Canada.

Assembly Tips



Helpful Hints

PEOPLE NEEDED FOR ASSEMBLY: **1-2**
ESTIMATED ASSEMBLY TIME: **1 HOUR**

- Open your item in the area you plan to keep it to avoid excessive heavy lifting.
- Identify, sort and count the parts before attempting assembly.
- Compression dowels are lightly tapped in with a hammer.
- Slides are labeled with a **R** (right) and **L** (left) for proper placement.
- Make sure to always face the point on the top of the Cam Lock towards the outer edge.
- Use all the nails provided for the back panel and spread them out equally.
- Back panel must be used to make sure your unit is sturdy.
- Do NOT use harsh chemicals or abrasive cleaners on this item.
- Never push, pull, or drag your furniture.



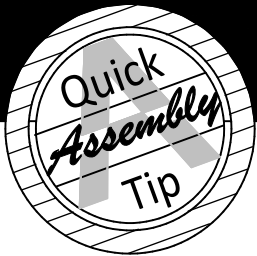

Before You Start

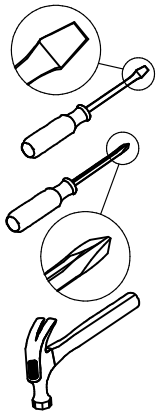

- ✓ Read through each step carefully and follow the proper order
- ✓ Separate and count all your parts and hardware
- ✓ Give yourself enough room for the assembly process
- ✓ Have the following tools: Flat Head Screwdriver, #2 Phillips Head Screwdriver and Hammer
- ✓ Caution: If using a power drill or power screwdriver for screwing, please be aware to slow down and stop when screw is tight. Failure to do so may result in stripping the screw.

Cam Lock Fastening System

This Cam Lock Fastening System will be used throughout the assembly process.

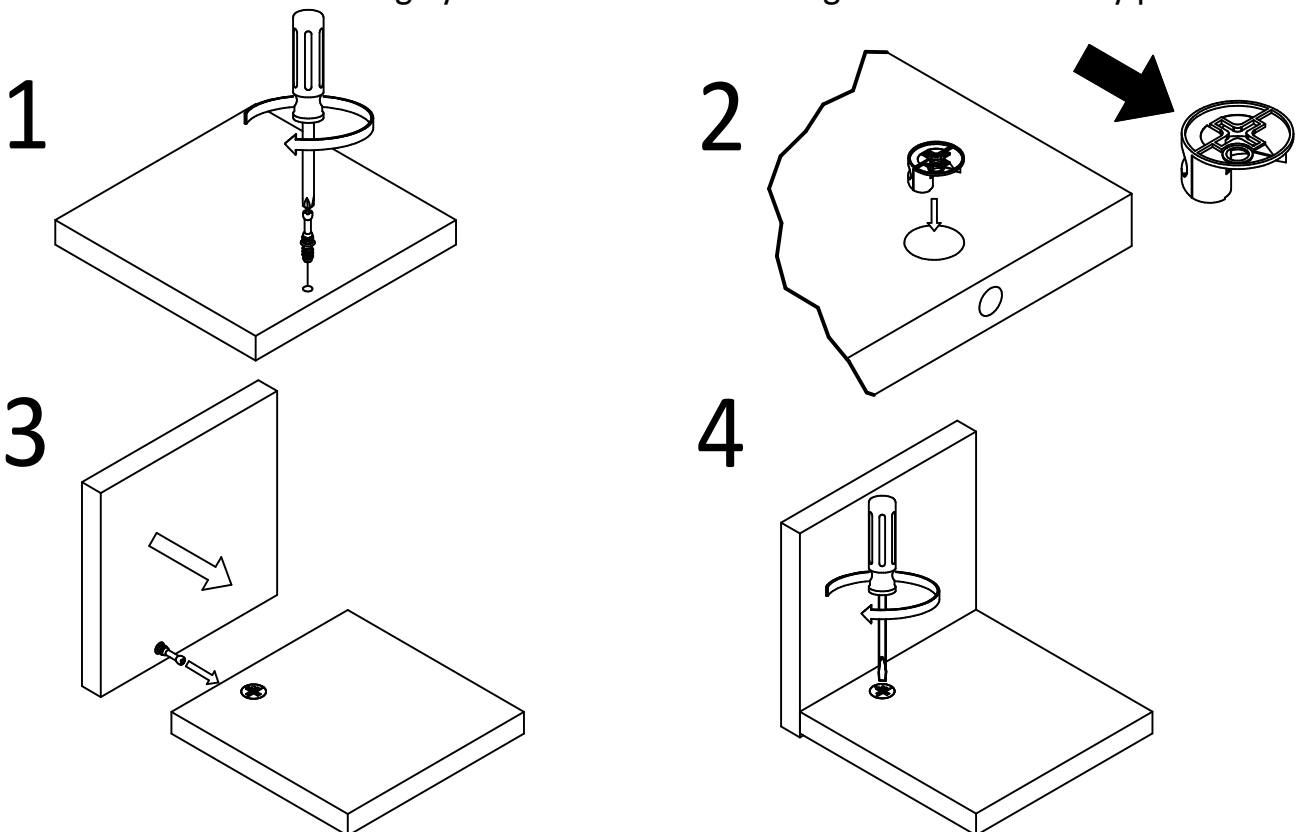

Board Identification

Not actual size

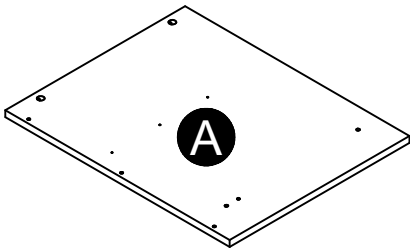

Left Panel
35759337010

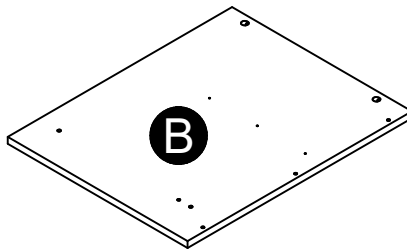

Right Panel
35759337020

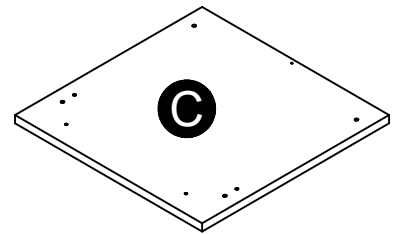

Top
35759337030

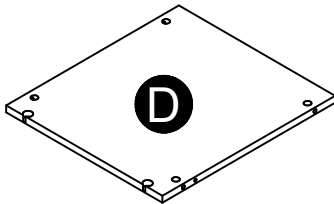

Bottom
35759337040

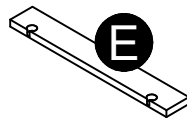

Upper Rail
35759337050

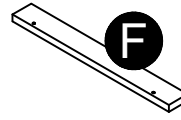

Lower Rail
35759337060

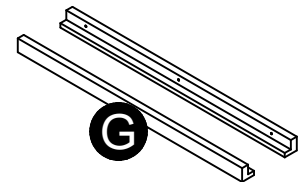

Vertical Molding (2)
35759337070

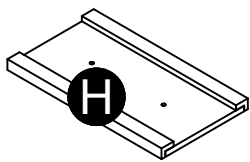

Drawer Front
35759337081

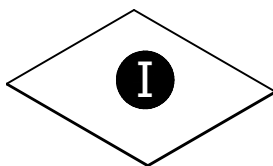

Drawer Bottom
35759331090



Drawer Back
39991167036740B

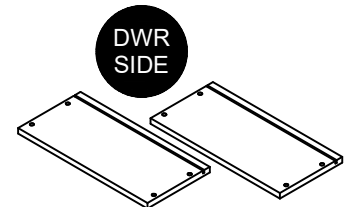

Drawer Side (2)
39991167346200C

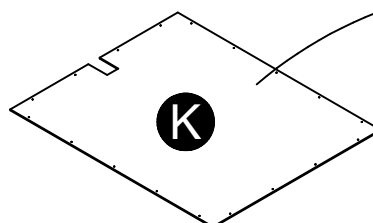

This piece is paperboard construction. it is not made from wood, but is required for the assembly of your unit.

Back Panel
K575933700

Board Identification

Not actual size

This piece is paperboard construction.
it is not made from wood, but is
required for the assembly of your unit.

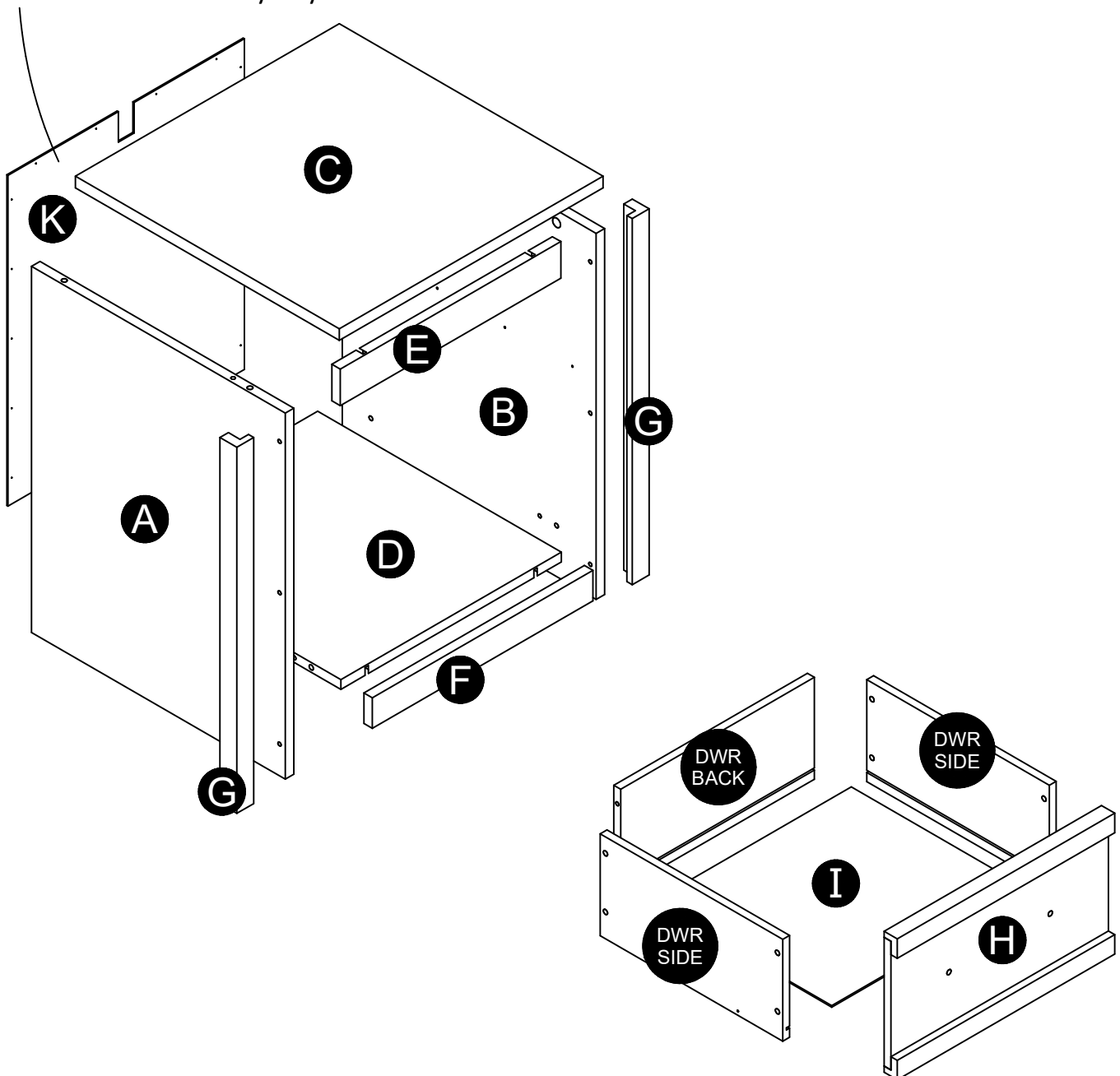

Part List

Actual Size

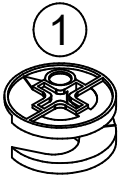

(x8)
#A22620
cam lock

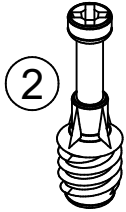

(x8)
#A22610
cam bolt



(x4)
#A21660
wood dowel

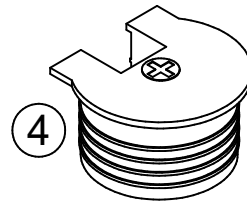

(x4)
#A22920
connector



(x4)
#A22910
connector bolt

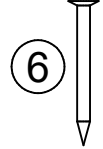

(x18)
#A21110
nail

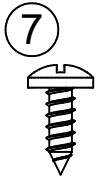

(x8)
#A12120
7/16" pan head

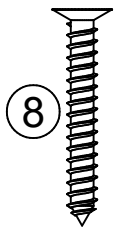

(x6)
#A12955
#8x1-1/8"
flat head

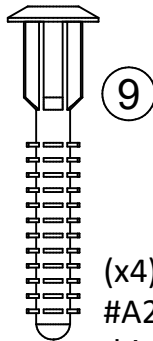

(x4)
#A21970
drive fastener

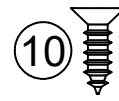

(x10)
#A11080
7/16" flat head



(x2)
#A17100
bolt

Not Actual Size

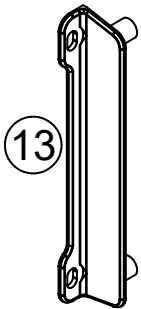

(x2)
#A54520
drawer bracket

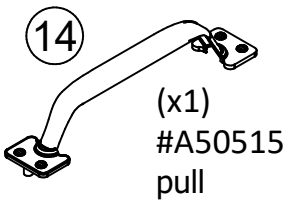

(x1)
#A50515
pull

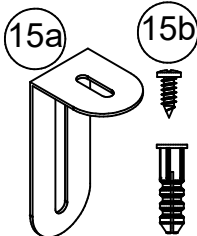

(x1)
#A84050
anti-tip kit



15c



15d

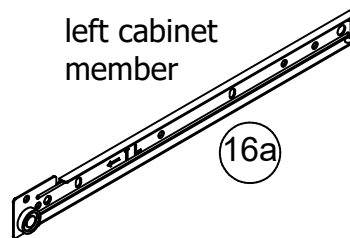

left cabinet member

16a

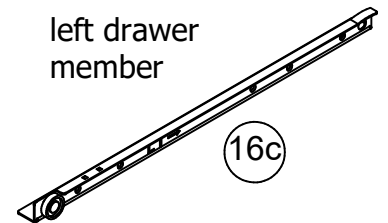

left drawer member

16c

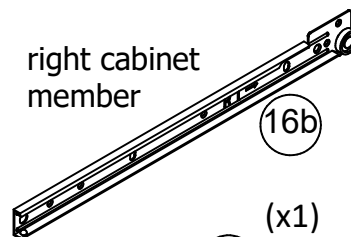

right cabinet member

16b

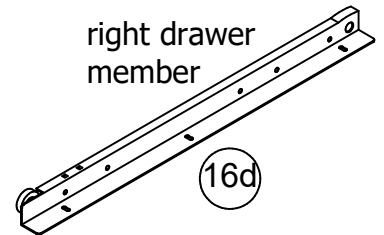

right drawer member

16d

(x1)
#A56770
drawer slide kit

STEP 1

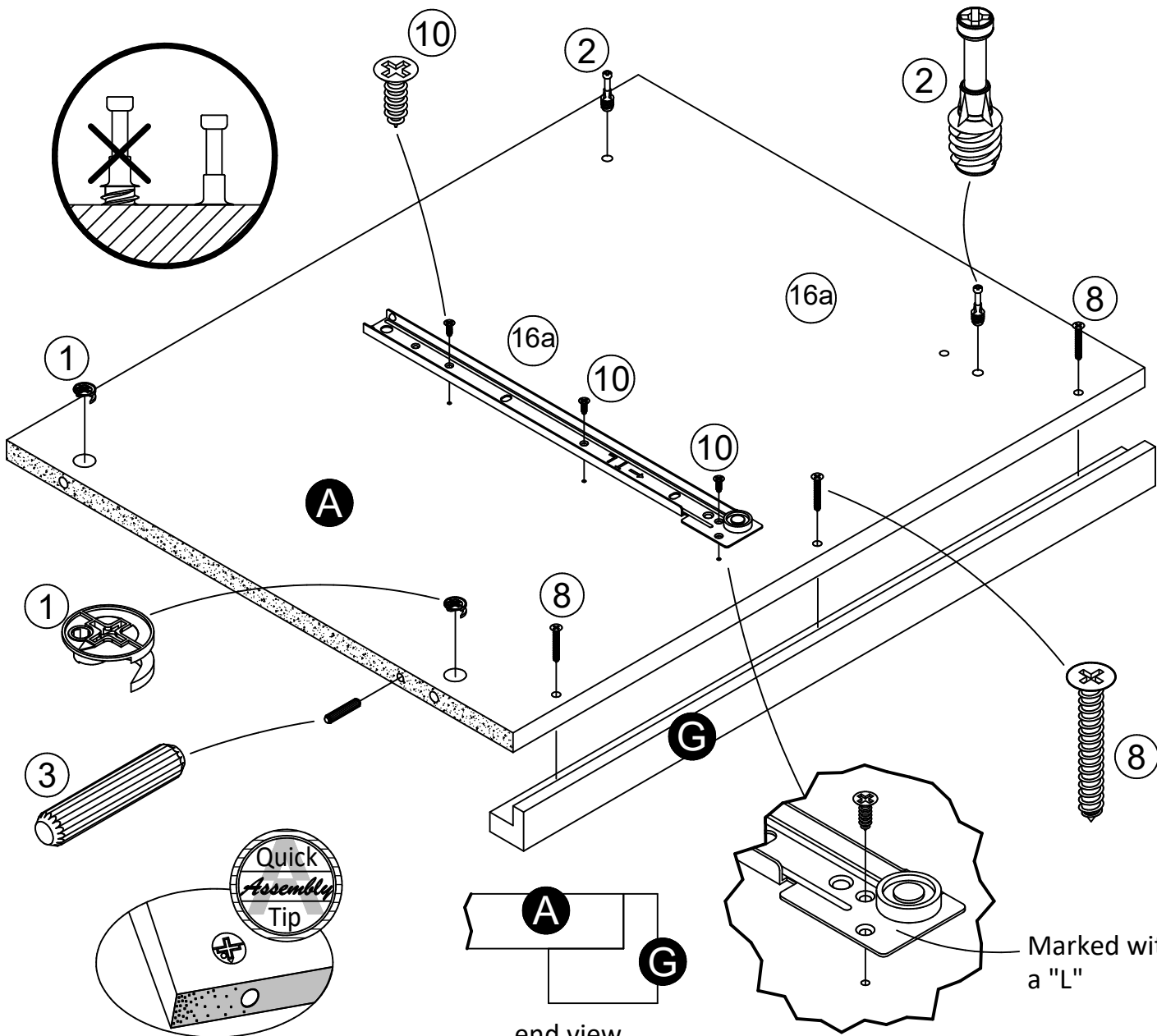
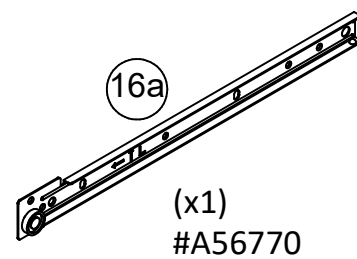
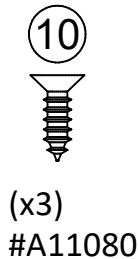
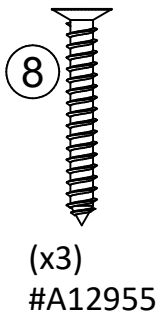
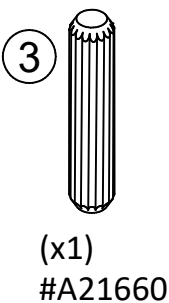
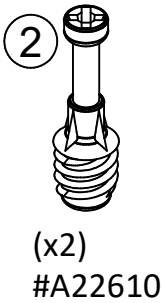
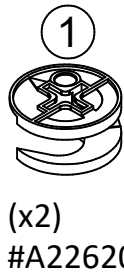
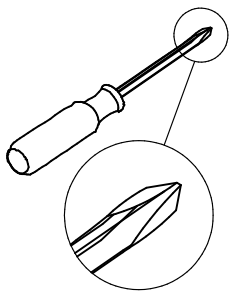

Proper orientation of CAM LOCK

end view

Marked with a "L"

* raw edges are shaded

STEP 2

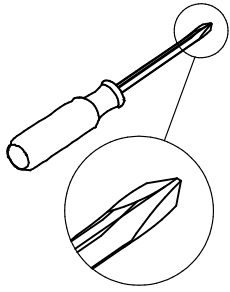

①
(x2)
#A22620

②
(x2)
#A22610

③
(x1)
#A21660

⑧
(x3)
#A12955

⑩
(x3)
#A11080

⑩
(x1)
#A56770

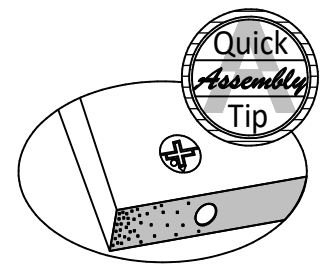
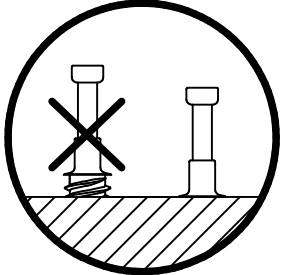

Proper orientation of CAM LOCK

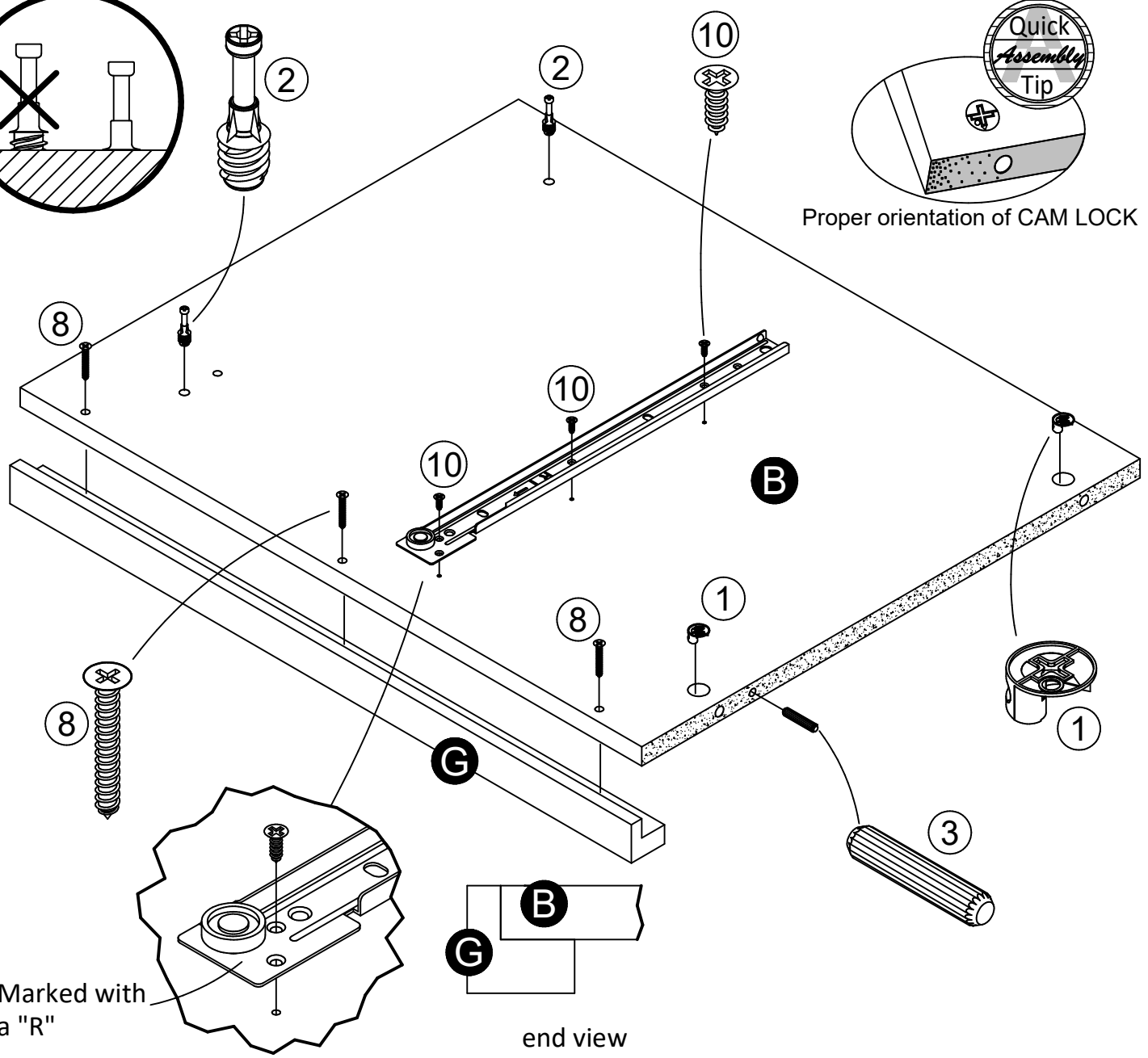

Marked with a "R"

end view

* raw edges are shaded

STEP 3

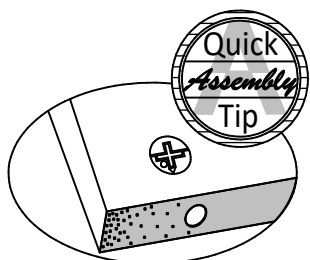
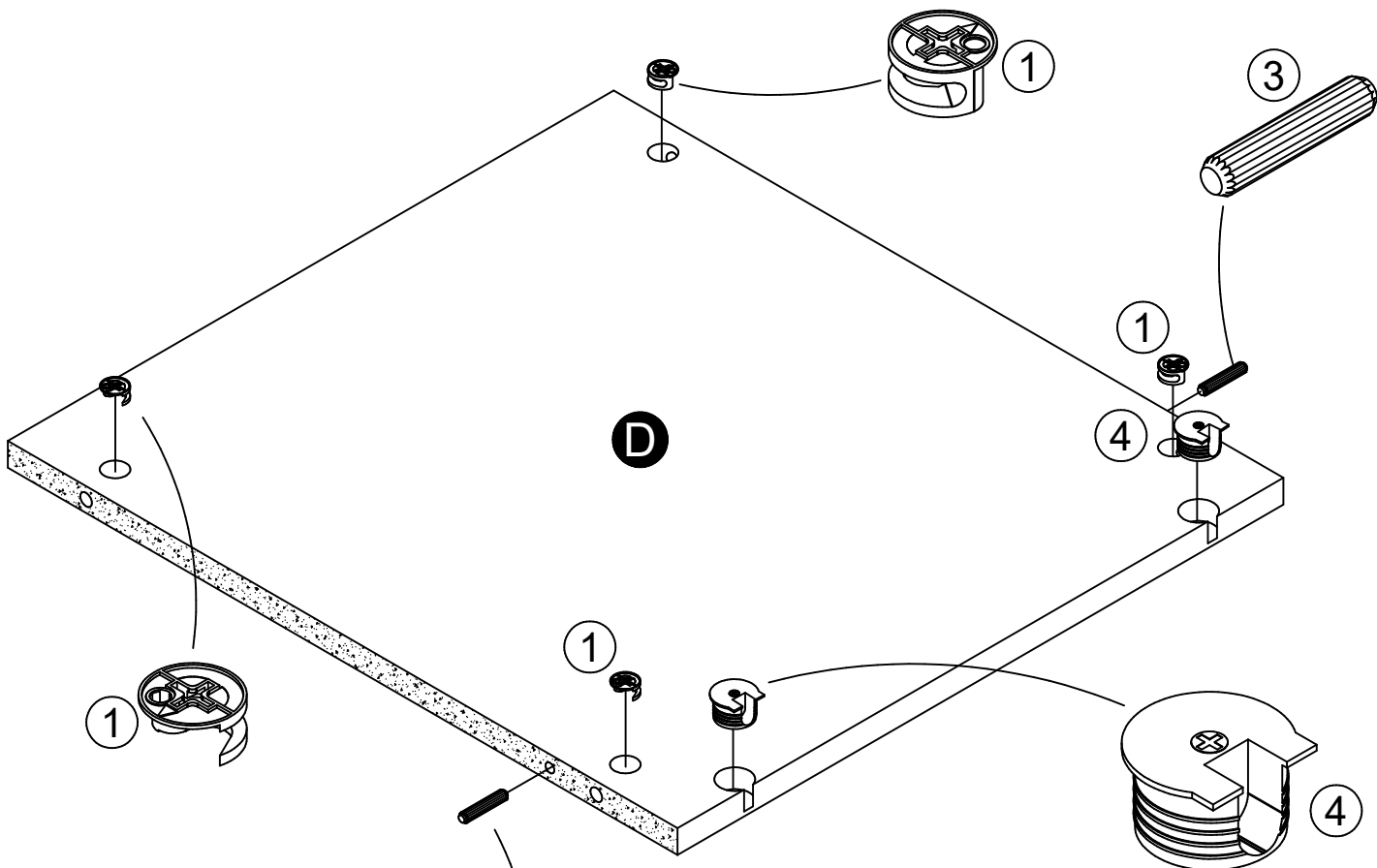
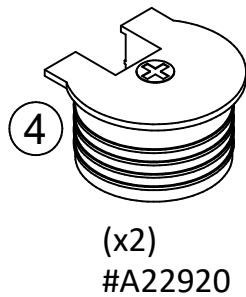
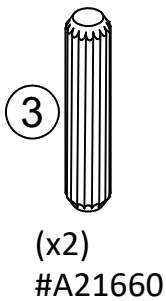
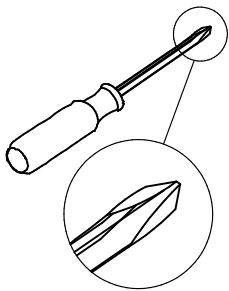

Proper orientation of CAM LOCK

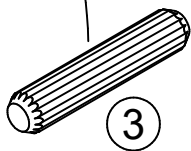

* raw edges are shaded



You will need to tap the connector with a hammer to fully insert. Be sure the connector is positioned as shown before pushing into holes.

STEP 4

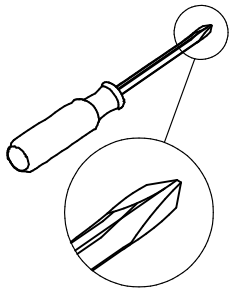

(x2)
#A22910

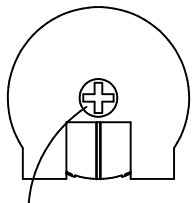
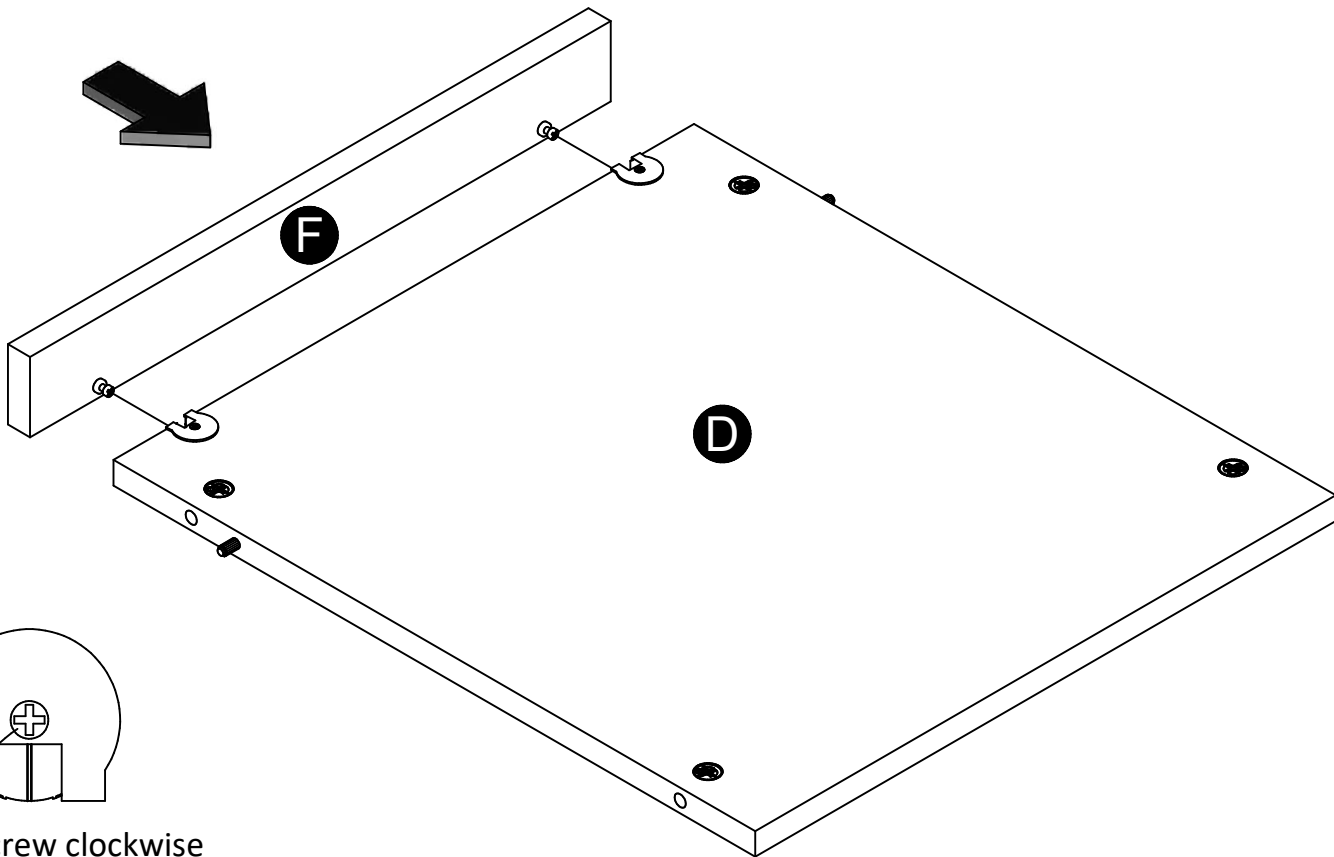
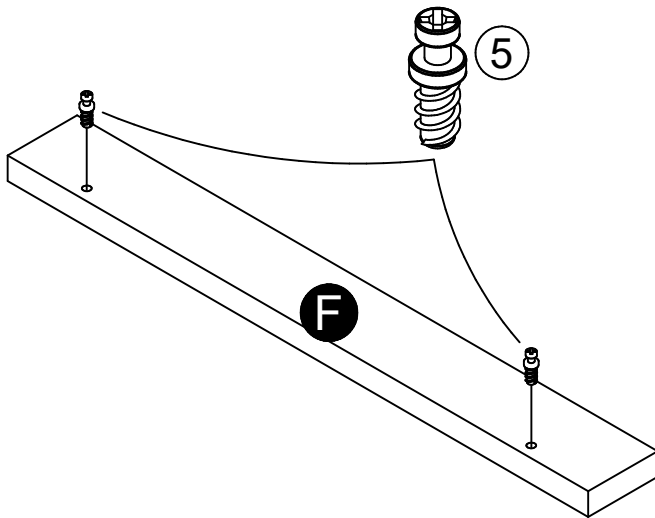

Turn screw clockwise
to lock in place.

* raw edges are shaded

STEP 5

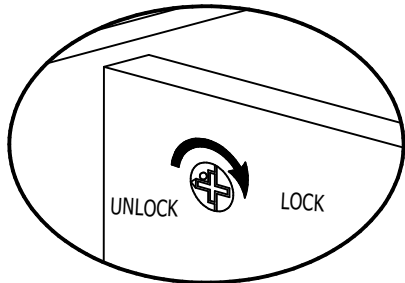
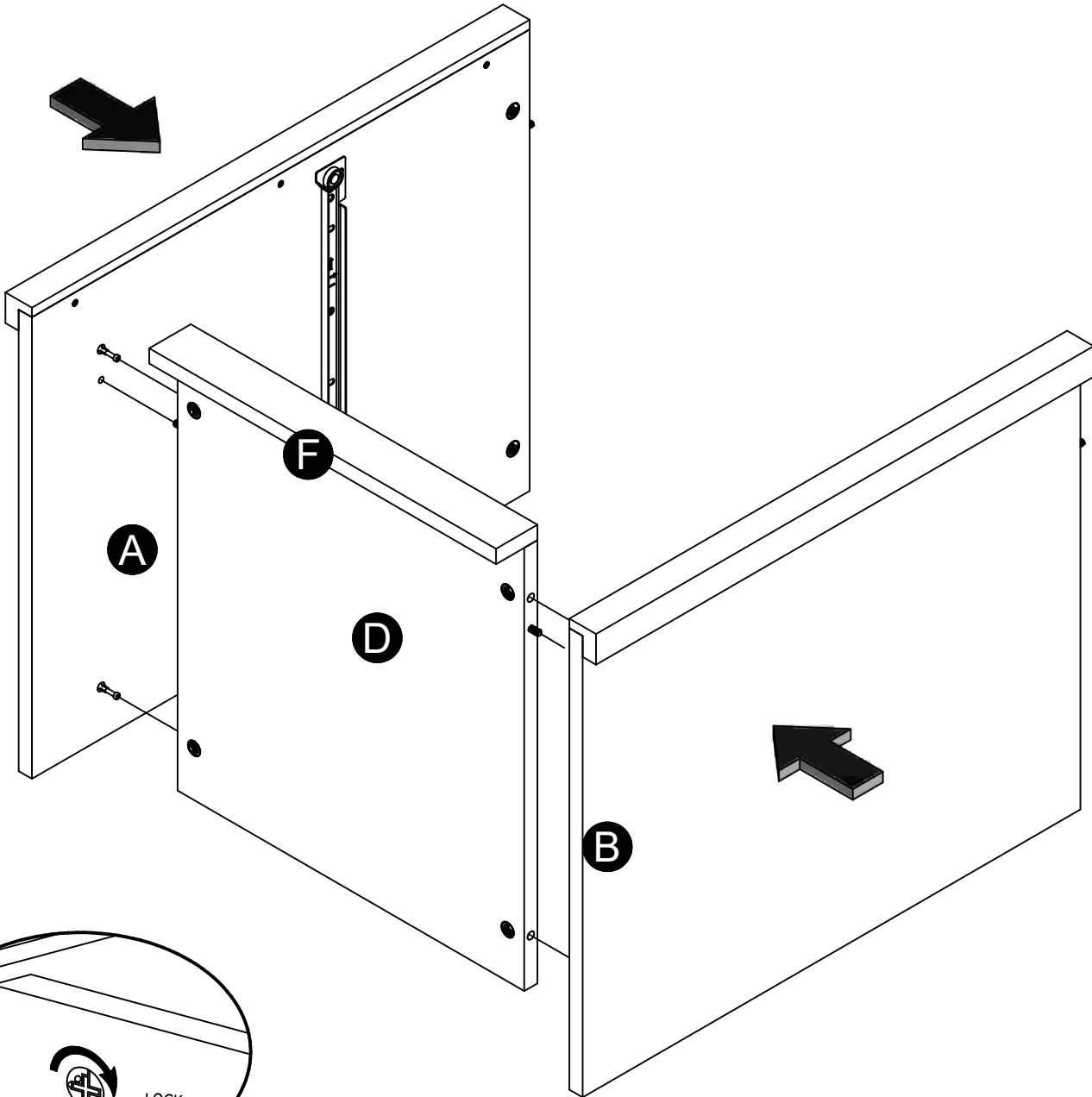
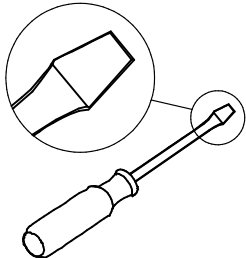

STEP 6

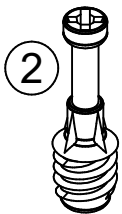
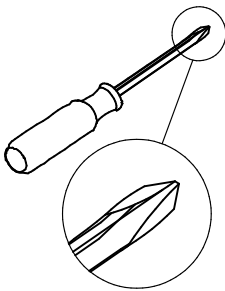

(x4)
#A22610

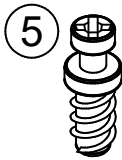

(x2)
#A22910

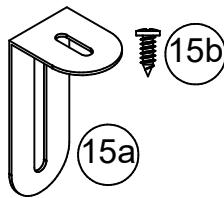

(x1)
#A84050

Do not fully tighten
this screw in this
step.

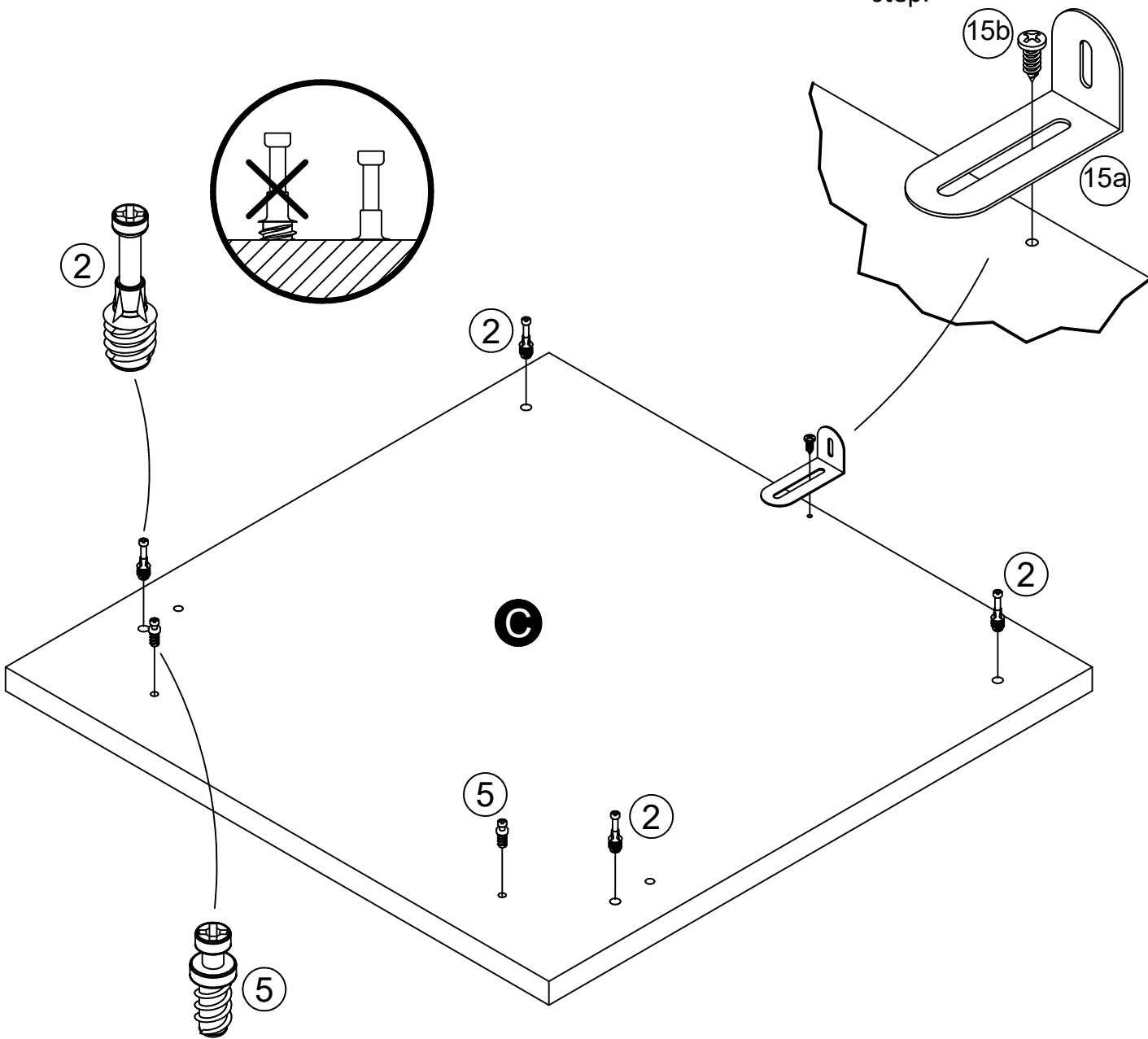

STEP 7

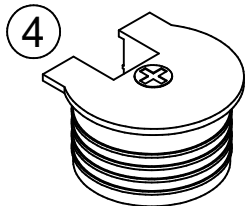
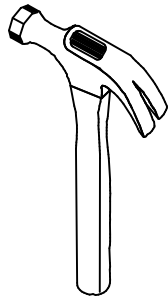
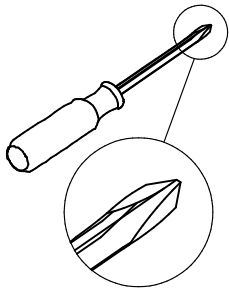

(x2)
#A22920

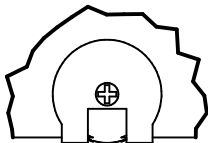

You will need to tap the connector with a hammer to fully insert. Be sure the connector is positioned as shown before pushing into holes.

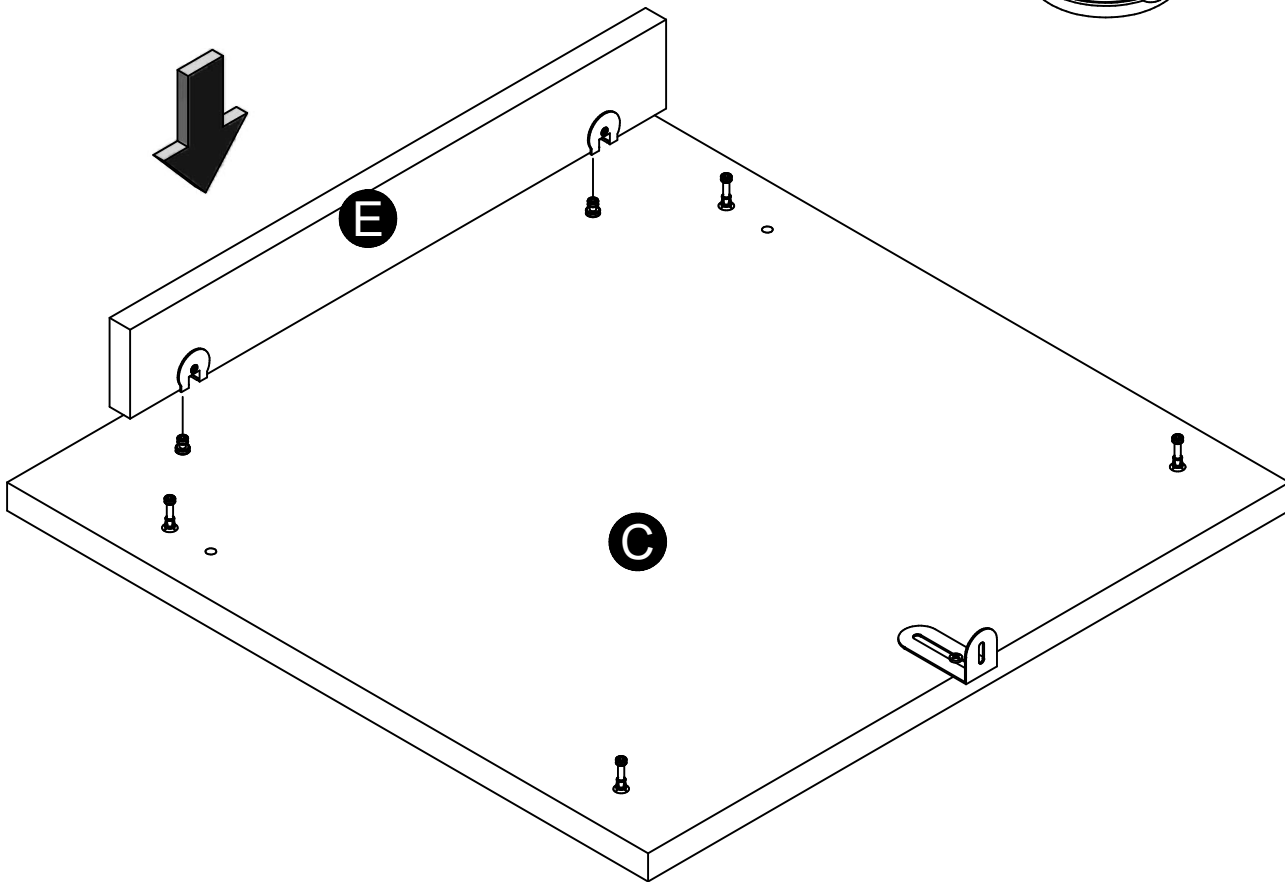
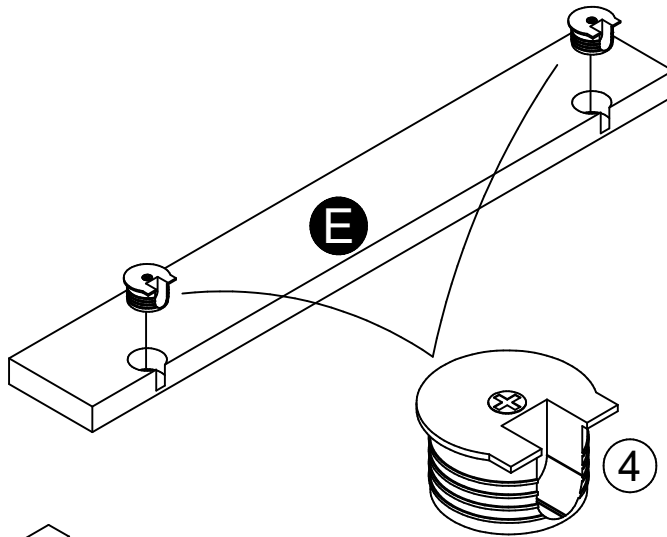

STEP 8

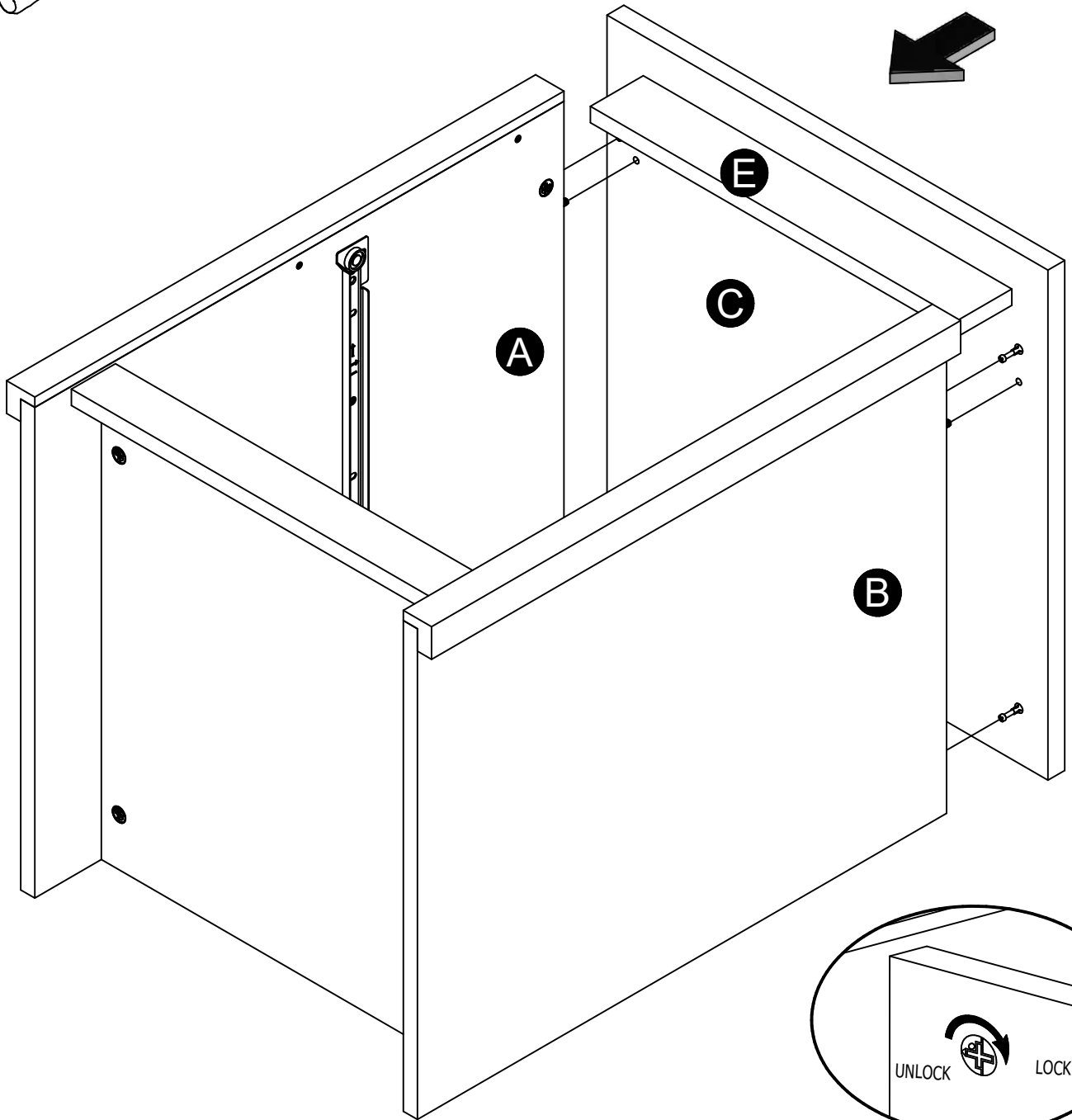
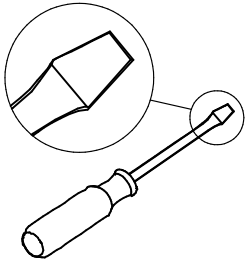

STEP 9

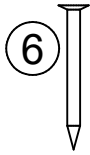
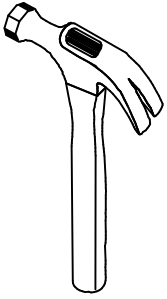

(x18)
#A21110

IMPORTANT! THE BACK PANEL IS A STRUCTURAL PART OF THIS UNIT AND MUST BE INSTALLED PROPERLY.

With the help of another person, carefully turn the unit over. Attach the back panel as shown nailing straight into the raw edges.

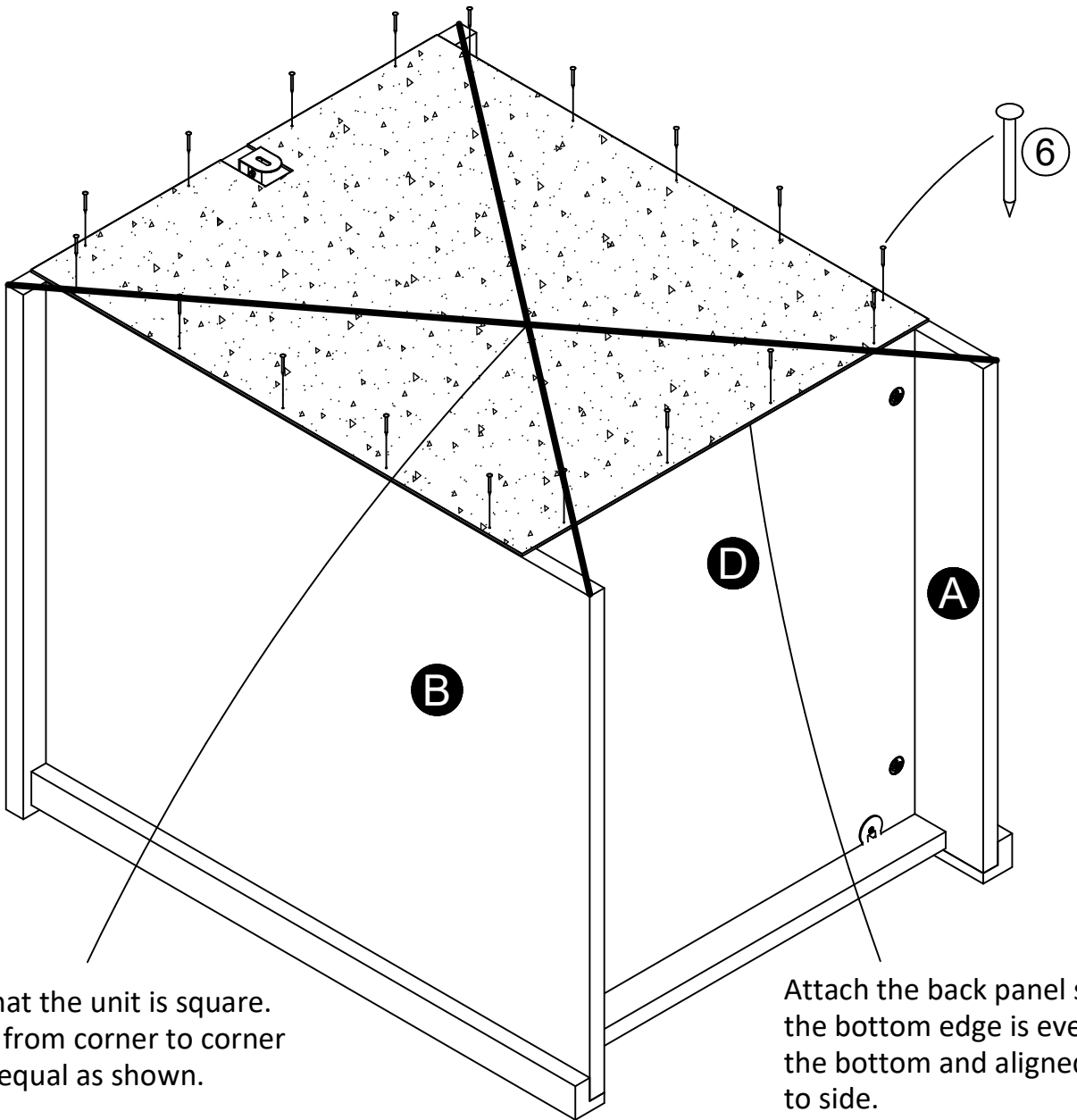

Assure that the unit is square. Distance from corner to corner must be equal as shown.

Attach the back panel so that the bottom edge is even with the bottom and aligned side to side.

* raw surface is shaded

STEP 10

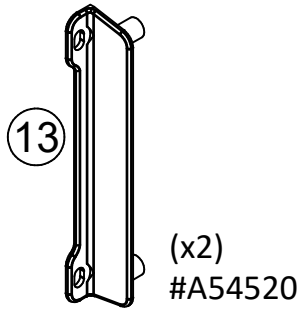
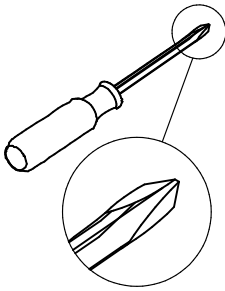

Line up the drawer bracket stem (13) with the holes in the drawer side as shown. From other side, insert screws (7) into drawer bracket stem and tighten.

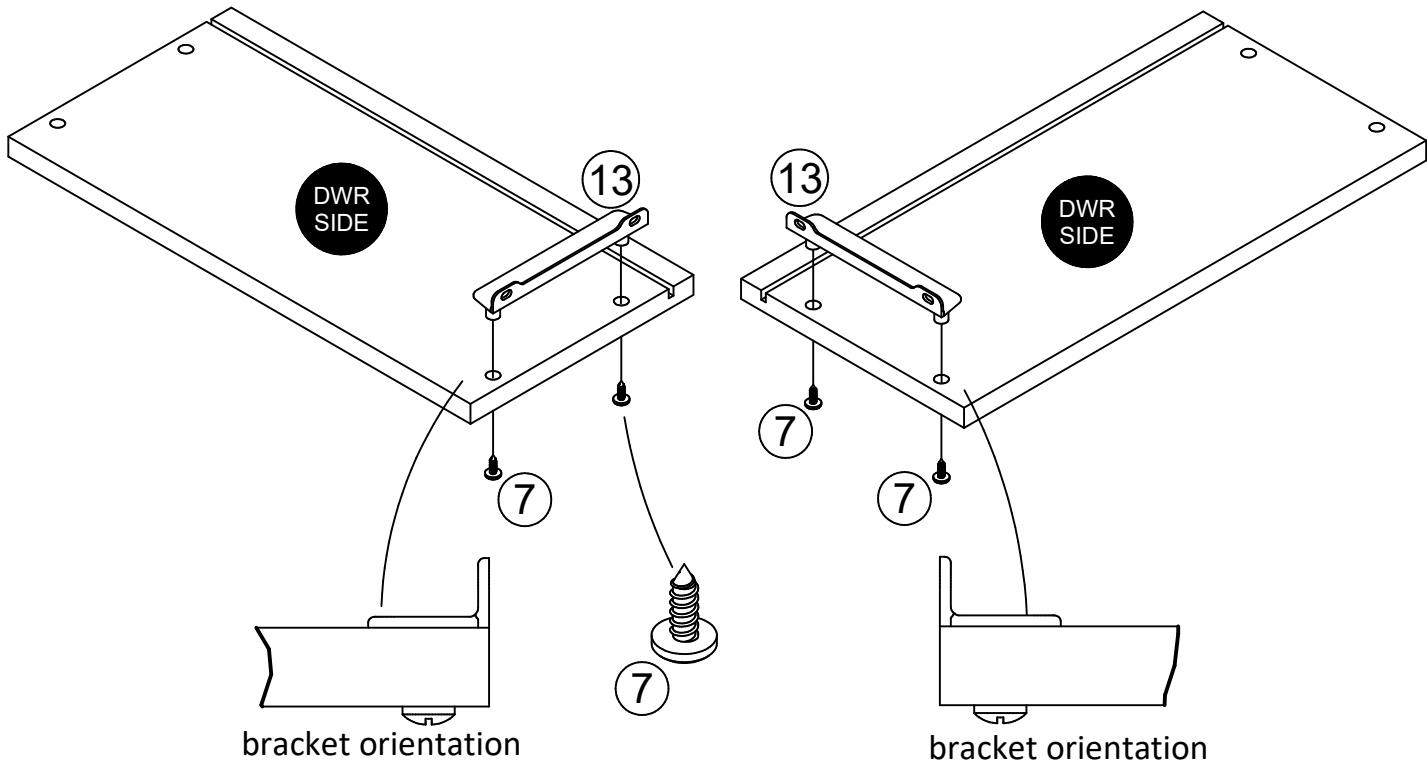

STEP 11

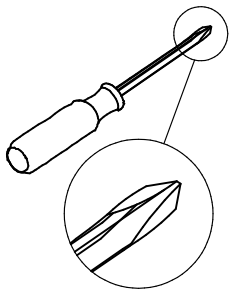

7
(x4)
#A12120

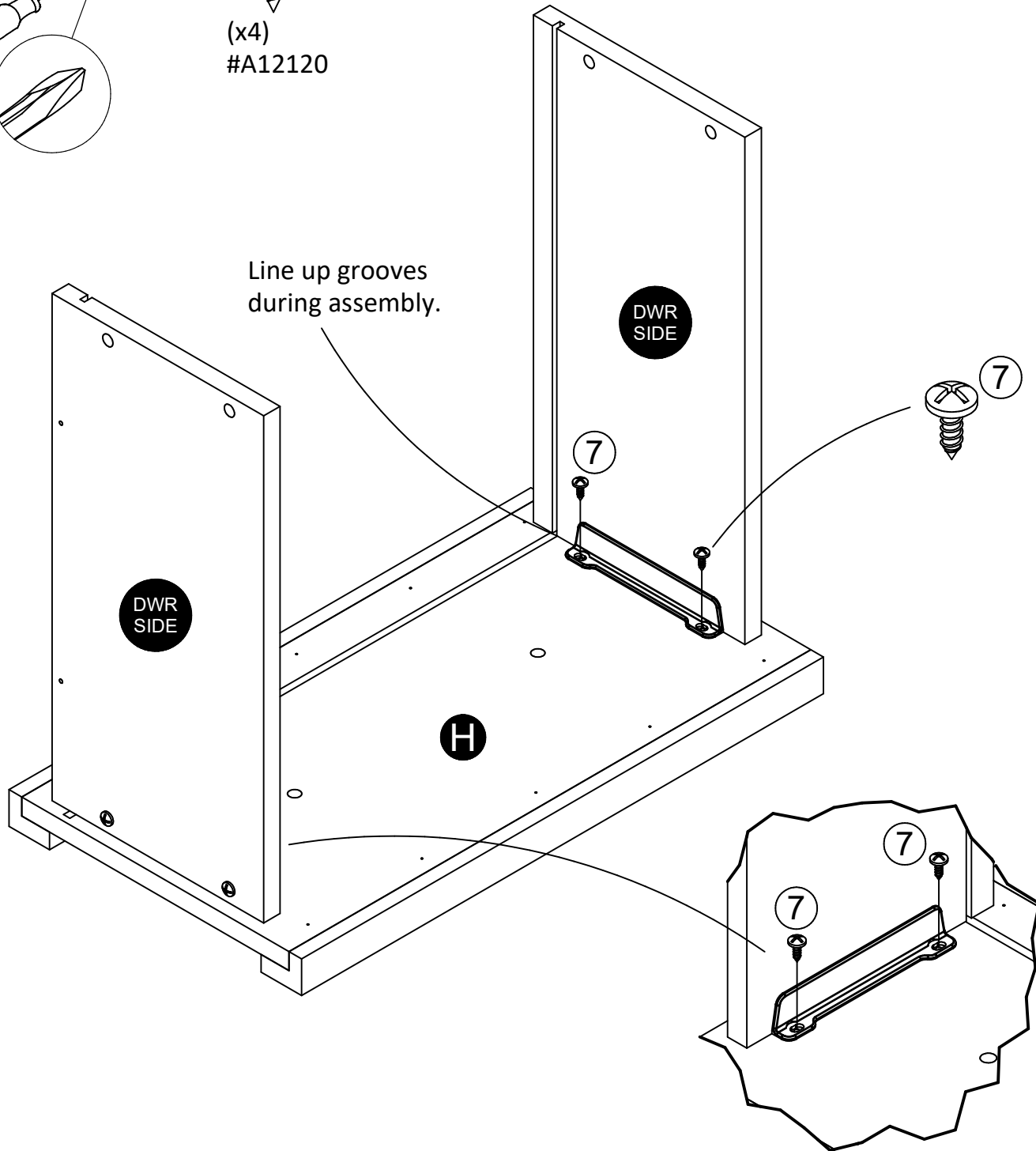

STEP 12

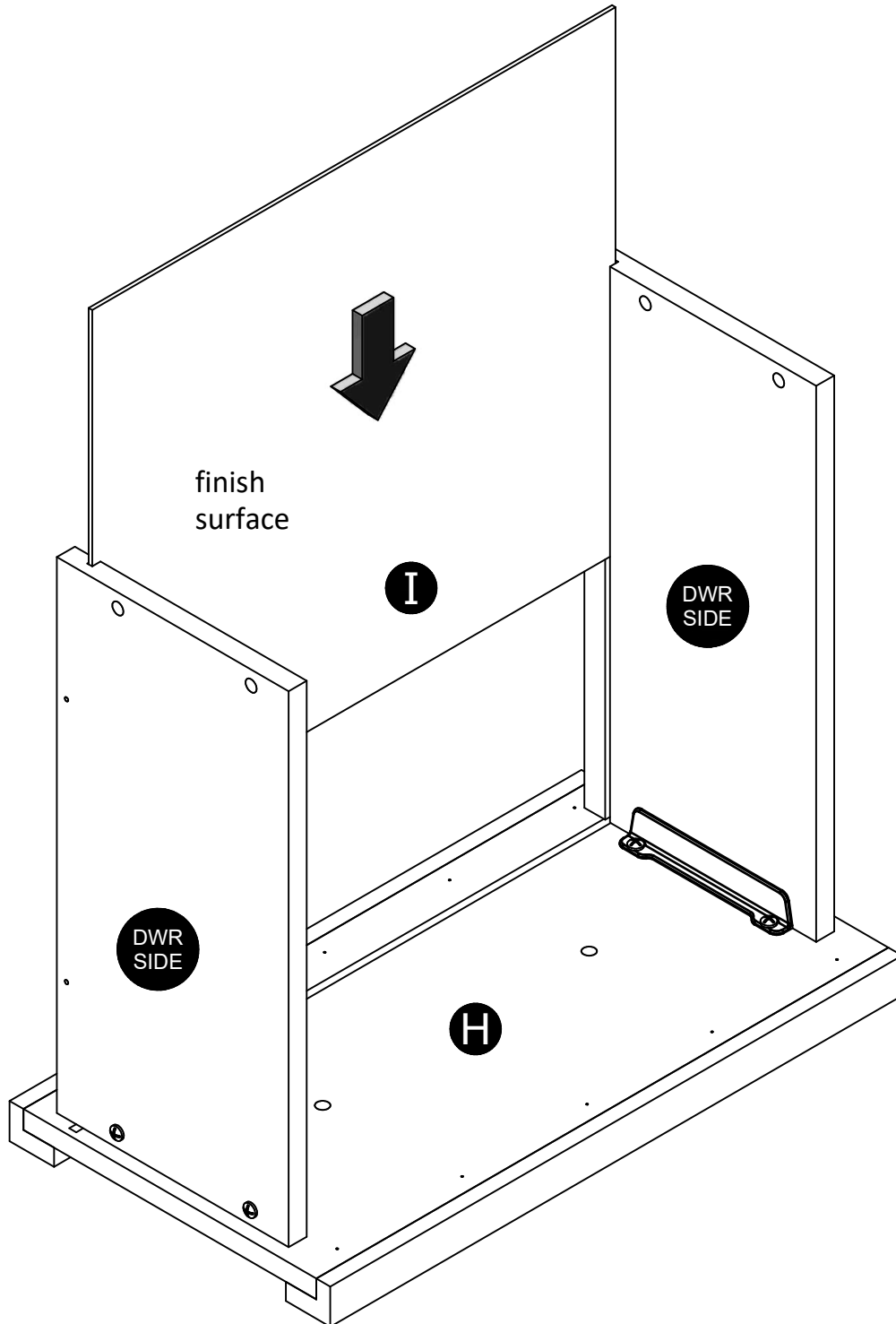

STEP 13

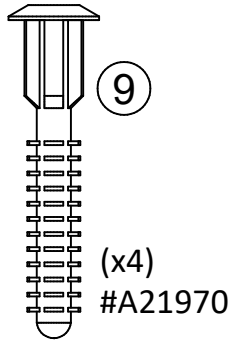
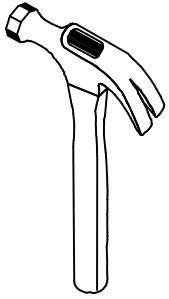

You will need to tap the drive fasteners (9) with a hammer to securely fasten.

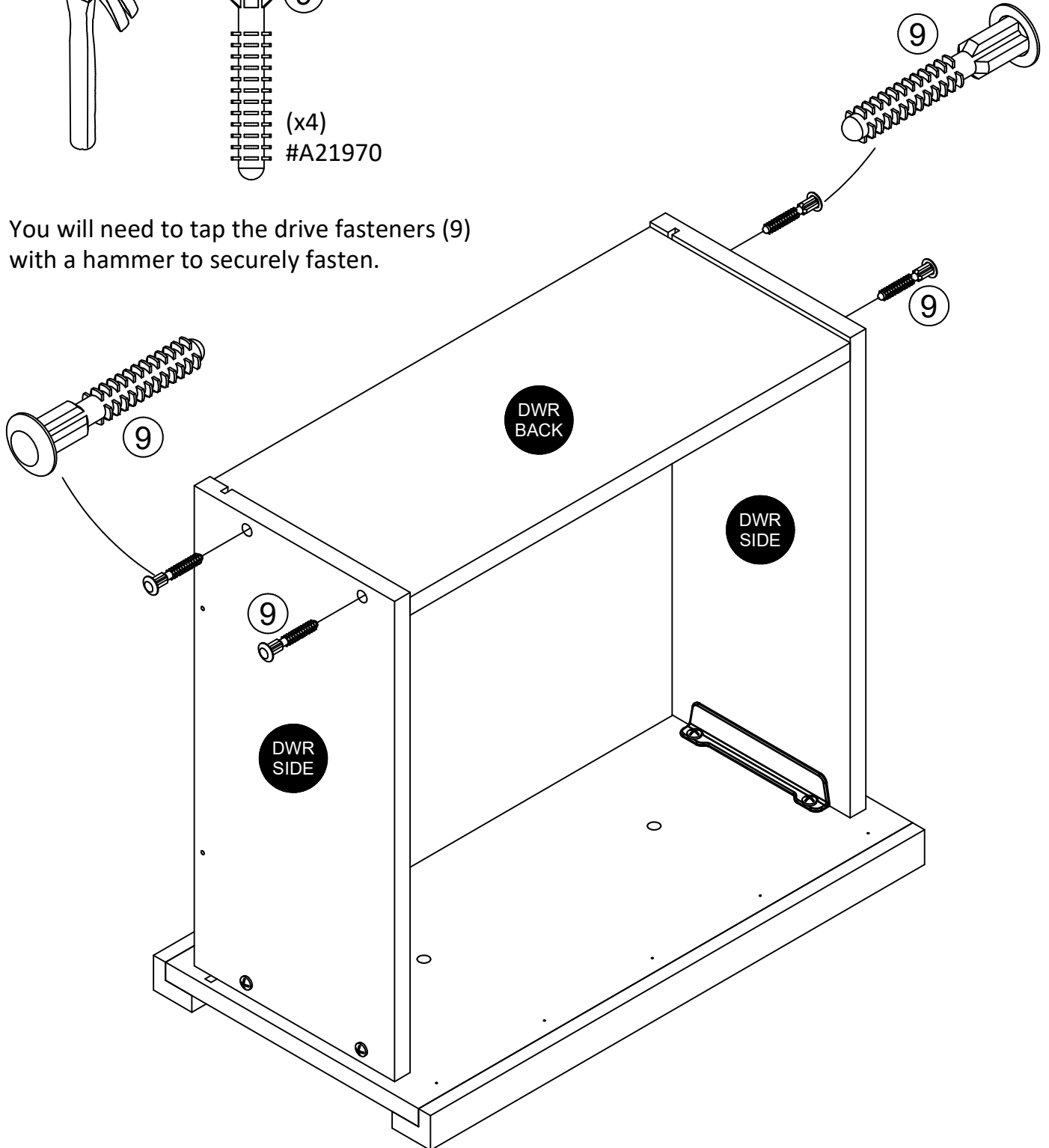

STEP 14

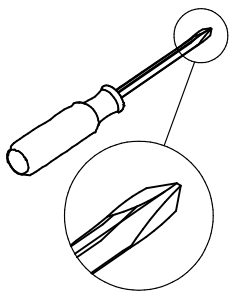

10
(x4)
#A11080

11
(x2)
#A17100

14
(x1)
#A50515

16c
(x1)
#A56770
drawer slide kit

Attach the pull (14) after attaching the drawer slides (16c), (16d).

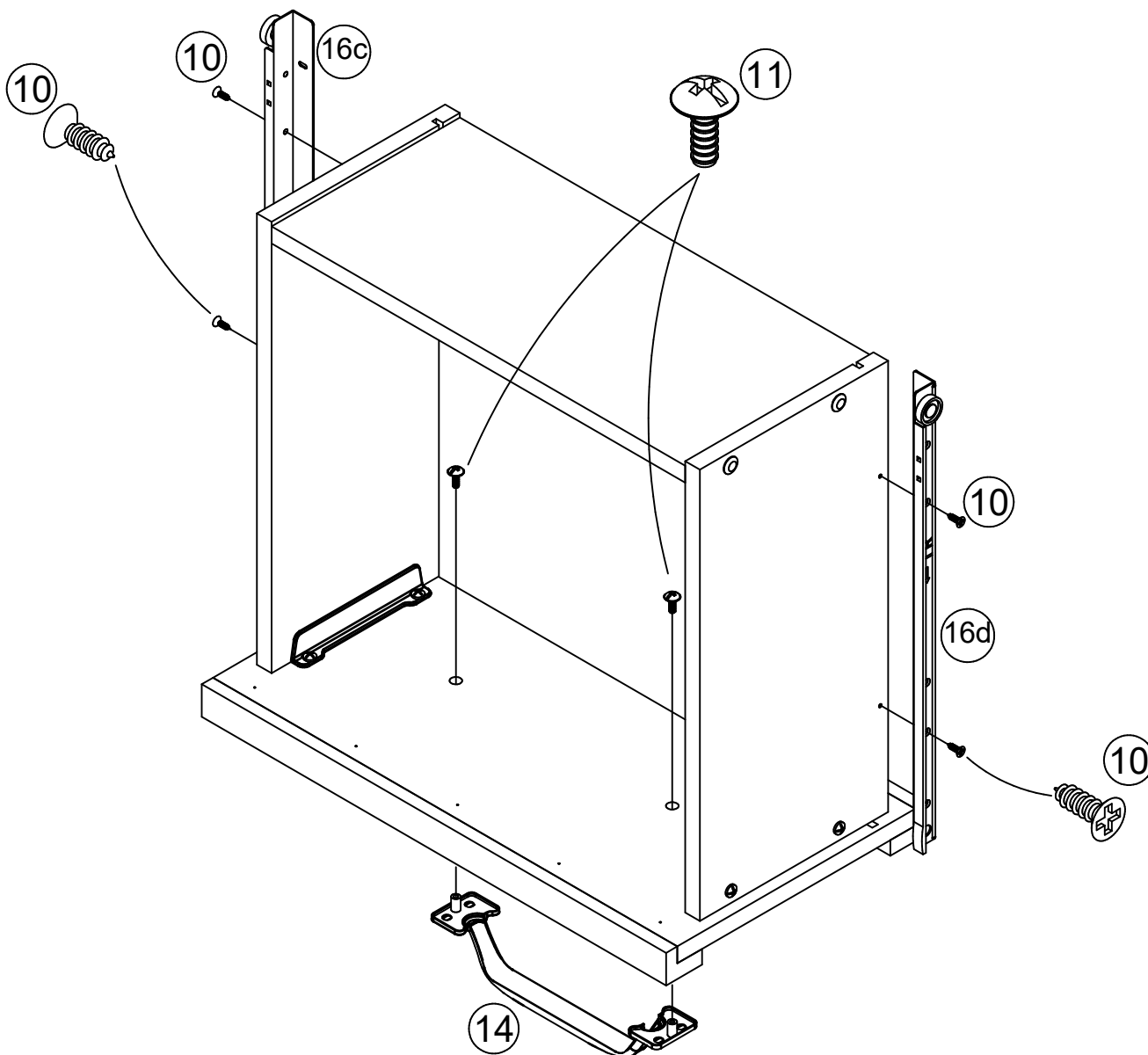

STEP 15

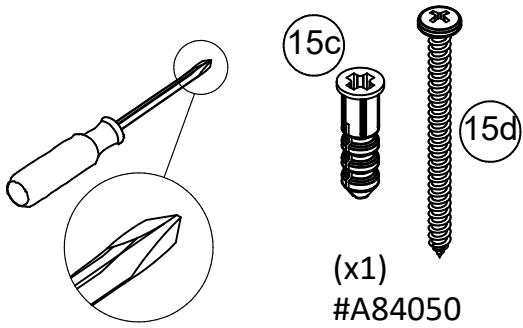

IMPORTANT: THIS UNIT MUST BE SECURE TO THE WALL TO HELP PREVENT TIPOVER. FOLLOW THESE INSTRUCTIONS TO INSTALL THE ANTI-TIPPING SAFETY BRACKET PROVIDED WITH THIS PRODUCT.

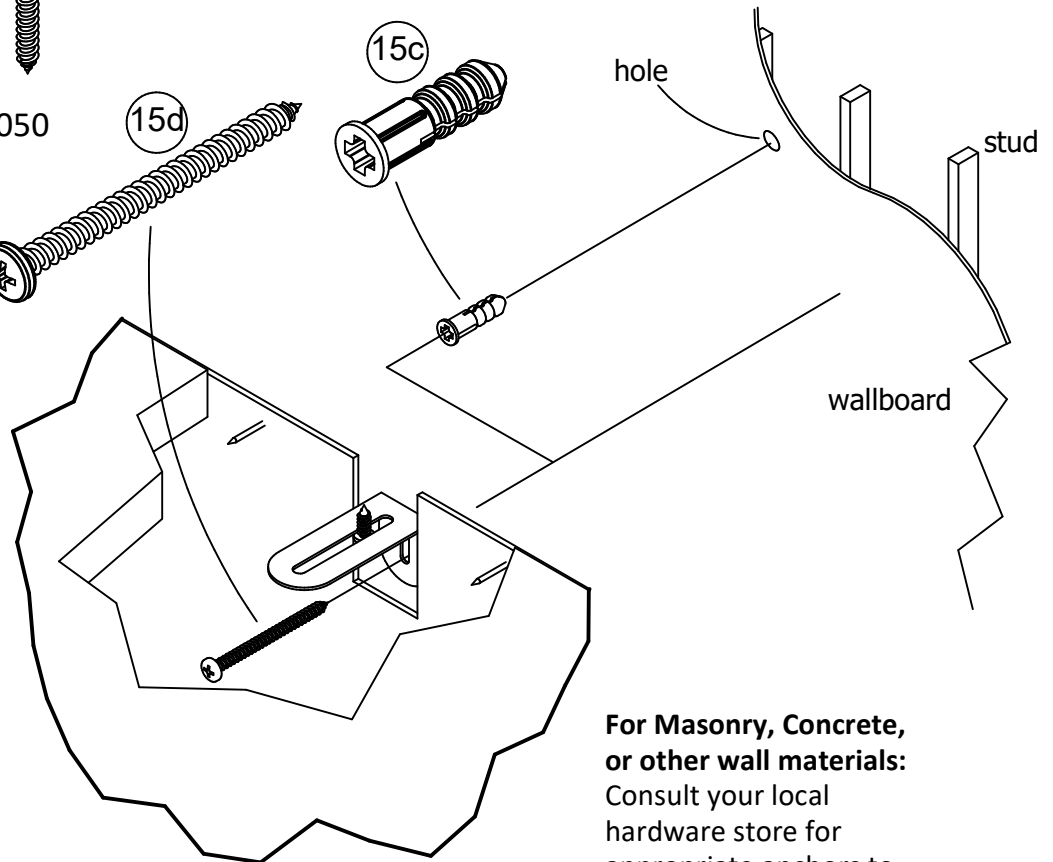

WARNING

Serious or fatal crushing injuries can occur from furniture tip over.

To prevent tip over:

- * Install tip over restraint provided
- * Unless specifically designed to accommodate, do not set TVs or other heavy objects on the top of this product
- * Never allow children to climb or hang on drawers, door, or shelves

Use of tip over restraints may only reduce, but not eliminate the risk of tip over

For Masonry, Concrete, or other wall materials:

Consult your local hardware store for appropriate anchors to securely attach the safety bracket.

OPTION 1: Attachment into a wall stud (preferred method)

Using a stud finder, locate a stud in the wall. Place your unit against the wall, with the safety bracket aligned in this location.

To make driving the screw easier, you can drill a 1/8" diameter pilot hole (3mm) through the safety bracket into the stud.

Drive the screw through the safety bracket into the wall stud. Tighten the screw that was not fully tightened in step 6.

OPTION 2: Attachment into drywall

Locate your unit where desired against a wall and mark the wall through the safety bracket, then move your unit aside. Drill a 3/16" diameter hole (5mm) into the wallboard. Tap the wall anchor into the hole until it is flush.

Move your unit into location and fasten the wall bracket to the wall anchor with the screw.

Tighten the screw that was not fully tightened in step 6.

STEP 16

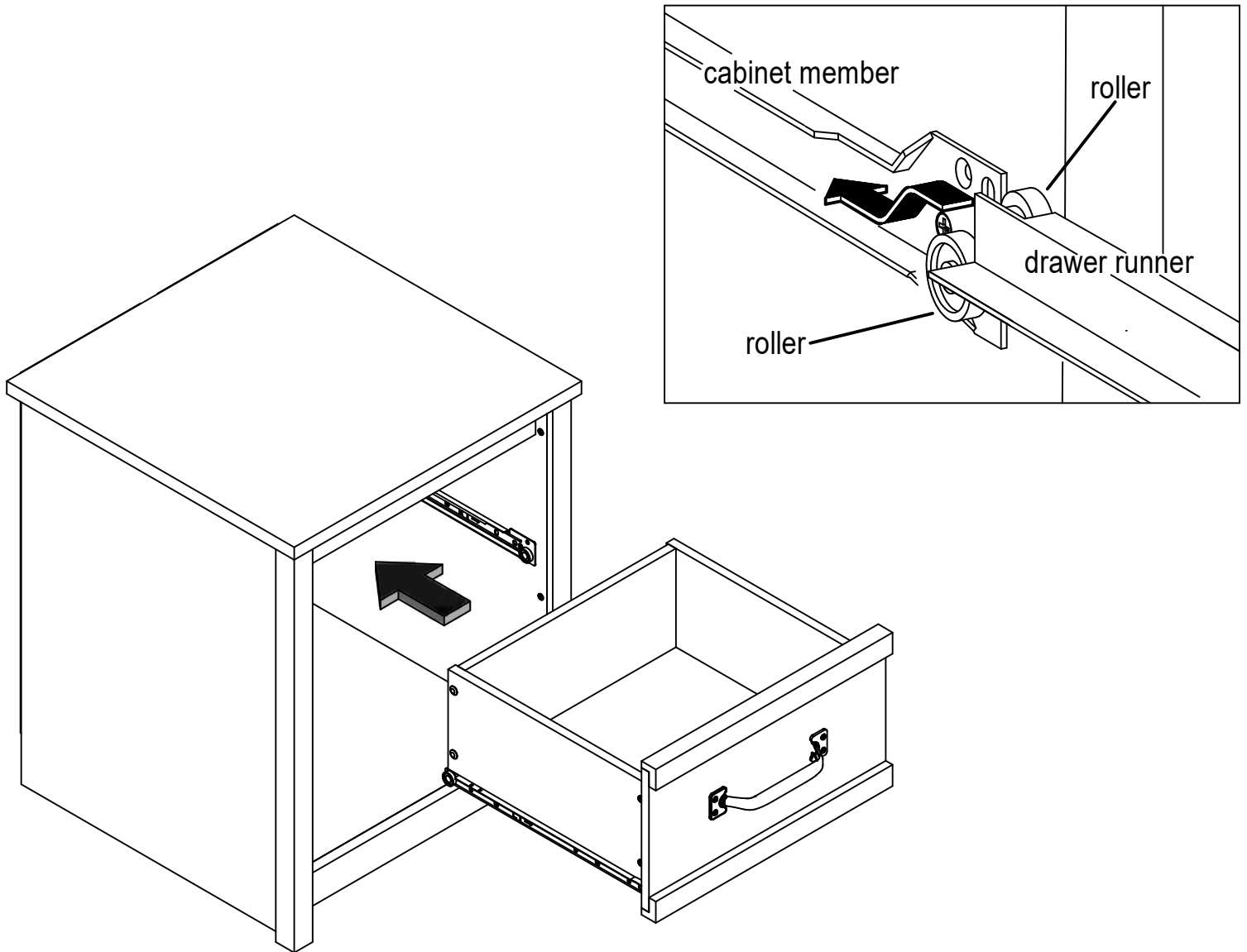

Notice, the drawer bracket holes are slotted. Drawer fronts can be adjusted by loosening screws, making needed adjustments and retightening screws.

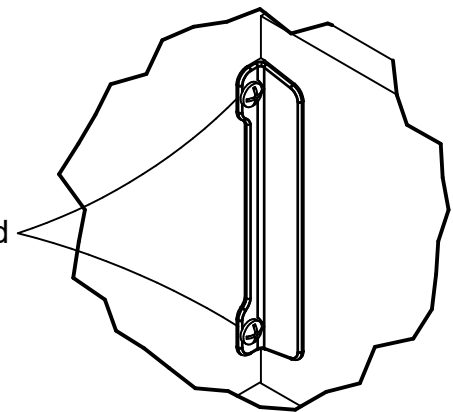

Maximum Loads

This unit has been designed to support the maximum loads shown. Exceeding these load limits could cause sagging, instability, product collapse, and/or serious injury.

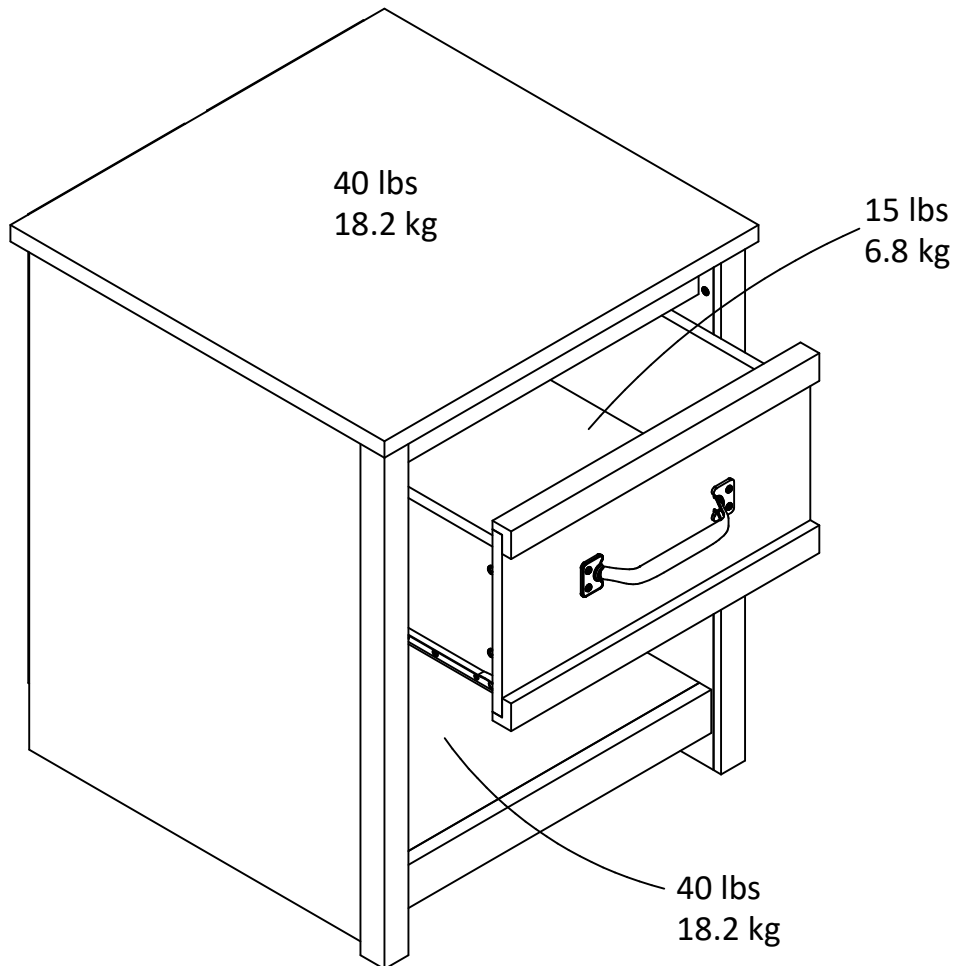

Warning: Risk of injury to persons - do not place a television on this furniture. This furniture is not approved for use with a television.

Certificate of Conformity

1. This certificate applies to the Dorel Home Furnishings, Inc. product identified by this instruction manual.
2. This certificate applies to compliance of this product with the CPSC Ban on Lead-Containing Paint (16 CFR 1303).
3. This product is distributed by: Dorel Home Furnishings, Inc.
410 East First Street South
Wright City, MO 63390
636-745-3351
4. Site of Manufacture: Tiffin OH
5. See front page of instruction manual for date of manufacture.

Register your product to receive the following:



- * New trend details - sneak peek on what's new
- * Surveys - have a voice within our community
- * Exclusive deals and discount codes
- * Quick and easy replacement part service

To register your product, visit ameriwoodhome.com

5 Star Rating



Visit your local retailer's website, rate your purchased product and leave us some feedback!

We would like to extend a big "Thank You" to all of our customers for taking the time to assemble this Ameriwood Home product, and to give us your valuable feedback.

*Thank
You!*

Cubierta Delantera

Este libro de instrucciones contiene información **IMPORTANTE** de seguridad. Por favor lea y manténgalo para referencia en el futuro.

No Regrese este producto! Comuníquese con nuestro amigoso equipo de servicio al cliente para obtener ayuda.

Llámenos al: 1-800-489-3351 (Gratis) Lunes - Viernes 9am - 5pm CST

Visitar: www.ameriwoodhome.com

PRECAUCION

Este mueble puede volcarse y causar graves heridas y/o muerte.

Anclar el mueble a un poste de madera en la pared (si esto se requiere).

No Permita que los niños monten el mueble.

Mantenga los artículos más pesados en los cajones de abajo.

Consejos Útiles (página 2)

- Abra su artículo en el área donde usted planea utilizarlo para evitar levantar y moverlo menos
- Identificar, ordenar y contar las piezas antes de intentar ensamblar
- Las clavijas de compresión se golpean con un martillo
- Las diapositivas están marcadas con una R (derecha) y L (izquierda) para la colocación correcta
- Asegúrese de que siempre este el punto localizado en la parte superior de bloqueador de leva este volteado hacia borde exterior
- Utilizar todos los clavos para el panel de atrás y distribuirlos por igual
- El panel de atrás debe utilizarse para asegurarse de que la unidad quede fija y firme
- No use químicas fuertes ni limpiadores abrasivos en este artículo
- Nunca empuje, tire ni arrastre los muebles

Antes de Que Empieces (página 3)

- Lea cuidadosamente cada paso y siga el orden correcto
- Separar y contar todas sus piezas y hardware
- Dése suficiente espacio para el proceso de ensamble
- Tenga las siguientes herramientas: destornillador de cabeza plana, #2 cabeza Phillips
Destornillador y martillo
- Precaución: Si usa un taladro electrónico o un destornillador eléctrico para atornillar, por favor asegúrese que deje de atornillar cuando el tornillo este apretado. Fallar hacer esto puede causar barrer el tornillo.

Sistema de fijar el bloqueo de leva (página 3)

Este sistema de fijar el bloqueo de leva sera usado en todo el proceso ensamble.

Página 15

Conecte el panel trasero como se muestra clavando directamente en los bordes sin procesar.

Asegure que la medida es cuadrada.

Distancia de esquina a esquina debe ser igual como se muestra por favor.

IMPORTANT: El Panel trasero es una parte estructural de la unidad y debe ser instalado correctamente.

Página 16

Alinee el vástago del soporte del cajón (13) con los orificios en el lado del cajón como se muestra.

Desde el otro lado, inserte los tornillos (7) en el vástago del soporte del cajón y apriételes.

Página 19

Usted necesitará golpear los sujetadores de la unidad (9) con un martillo para sujetar firmemente.

Página 20

Fije el tirón (14) después de fijar las correderas del cajón (16C), (16d).

Página 21

Importante: esta unidad debe estar asegurada a la pared para ayudar a prevenir la vuelque. Siga estas instrucciones para instalar el soporte de seguridad contra volcaduras provisto con este producto.

ADVERTENCIA

Lesiones graves o fatales de aplastamiento pueden ocurrir a partir de la punta del mueble.

Para evitar la volcadura:

* Instale la extremidad sobre el alojamiento proporcionado

* A menos que se diseñe específicamente para acomodar, no fije los televisores u otros objetos pesados en la parte superior de este producto

* Nunca permita que los niños se suban o cuelguen de cajones, puertas o estantes

El uso de la punta sobre las restricciones sólo puede reducir, pero no eliminar el riesgo de vuelco

Opción 1: fijación en un montante de pared (método preferido)

Con un buscador de postes, localice un poste en la pared. Coloque la unidad contra la pared, con el soporte de seguridad alineado en este lugar.

Para facilitar la conducción del tornillo, puede taladrar un orificio piloto de 1/8 "de diámetro (3 mm) a través del soporte de seguridad en el montante.

Conduzca el tornillo a través del soporte de seguridad en el montante de pared. Apriete el tornillo que no estaba completamente apretado en el paso 6.

Opción 2: accesorio en drywall

Localice su unidad donde se desee contra una pared y marque la pared a través del soporte de seguridad, luego mueva su unidad a un lado.

Taladre un agujero de diámetro de 3/16 "(5 mm) en el panel de yeso. Golpee el ancla de pared en el agujero hasta que quede al ras.

Mueva su unidad a la posición y fije el soporte de pared al ancla de pared con el tornillo.

Apriete el tornillo que no estaba completamente apretado en el paso 6.

Para mampostería, hormigón u otros materiales de pared:

Consulte con su ferretería local para los anclajes apropiados para fijar firmemente el soporte de seguridad.

Página 22

Note, que los agujeros del soporte del cajón están perforados. La parte de enfrente de los cajones pueden ser ajustadas sin aflojan los tornillos, haga los ajustes necesarios y apriete los tornillos otra vez.

Note, que los agujeros del soporte del cajón están perforados. La parte de enfrente de los cajones pueden ser ajustadas sin aflojan los tornillos, haga los ajustes necesarios y apriete los tornillos otra vez.

Página 23

CARGA MAXIMA

Esta unidad ha sido diseñada para soportar la carga máxima anotada. El exceder estos límites puede causar inestabilidad, colapsarse y/o causar serias lesiones.

ADVERTENCIA: Riesgo de lesiones a las personas - no coloque un televisor sobre muebles. Este mueble no está aprobado para su uso con un televisor.

Página 24

Registre su producto para recibir lo siguiente:

- * Detalles de nuevas tendencias - Vistazo a lo nuevo
- * Encuestas - aloc su voz entre su comunidad
- * Códigos de ofertas y descuentos exclusivos
- * Fácil y rápido servicio de partes de remplace

Para registrar su producto, visite ameriwoodhome.com

Clasificación de 5 estrellas

Visite el sitio web de su tienda local, califique su comprado y denos sus comentarios!

Nos gustaría enviar un gran "Agradecimiento" a todos nuestros clientes por tomarse el tiempo de ensambalar este producto de Ameriwood Home, y por darnos sus valiosos comentarios.

Gracias

Couverture Avant

CE LIVRET D'INSTRUCTION CONTIENT DES INFORMATIONS **IMPORTANTES** SUR LA SÉCURITÉ. VEUILLEZ LIRE ET GARDER POUR UNE RÉFÉRENCE FUTURE

Ne retournez pas ce produit! Contactez notre équipe de service à la clientèle amicale d'abord pour obtenir de l'aide.

Appelez-nous: 1-800-489-3351 (sans frais) du Lundi au Vendredi de 9h à 17h Heure Centrale

Visitez: www.ameriwoodhome.com

ATTENTION

Le meuble peut basculer et causer des blessures graves ou la mort.

Ancrer le meuble à une planche murale dans le mur (si indiqué).

Ne laissez pas les enfants grimper sur le meuble.

Placez les articles lourds sur les étagères ou dans les tiroirs inférieurs.

Astuces Utiles (page 2)

-Ouvrez votre article dans la zone que vous prévoyez de le garder pour moins de levage lourd

-Identifier, trier et compter les pièces avant d'essayer d'assembler

-Les goujons de compression sont taraudés avec un Marteau

-Les glissières sont marquées d'un R (droit) et d'un L (gauche) pour un bon placement

-Assurez-vous toujours de faire face la pointe situé sur le haut de la Serrure de Came vers le bord extérieur

-Utiliser tous les clous fournis pour le panneau arrière et les répartir également

-Le panneau arrière doit être utilisé pour vous assurer que votre appareil est robuste

-N'utilisez pas de produits chimiques agressifs ou de nettoyeurs abrasifs sur cet appareil

-Ne jamais pousser, tirer, ou faire glisser votre meuble

Avant de Commencer (page 3)

-Lisez attentivement chaque étape et suivez le bon ordre

-Séparez et comptez toutes vos pièces et matériaux

-Donnez-vous suffisamment de place pour l'assemblage

-Avoir les outils suivants: tournevis à tête plate, #2 tournevis Phillips, et Marteau

-Attention: Si vous utilisez une perceuse électrique ou un tournevis électrique pour visser, veillez à ralentir et arrêter lorsque la vis est bien serrée. Le non-respect de cette consigne peut endommager la vis.

Système de Fixation de Came (page 3)

Ce Système de Fixation de Came sera utilisé tout au long de l'assemblage

Page 15

Attachez les panneaux arrière comme indiqué en cliquant directement dans les bords bruts.

Assurez-vous que le meuble est à égalité.

La distance de coin doit être égale comme montré.

IMPORTANT: Le panneau arrière est une partie structurelle de cet appareil et doit être installé correctement.

Page 16

Alignez la tige du support de tiroir (13) avec les trous du côté du tiroir, tel qu'illustré. De l'autre côté, insérez les vis (7) dans la tige du support de tiroir et serrez.

Page 19

Vous devrez taper les attaches d'entraînement (9) avec un marteau pour fixer solidement.

Page 20

Fixez la traction (14) après avoir attaché les glissières du tiroir (16C), (16d).

Page 21

IMPORTANT: cet appareil doit être bloqué au mur pour aider à prévenir la basculement. Suivez ces instructions pour installer le support de sécurité antibasculément fourni avec ce produit.

AVERTISSEMENT

Des blessures graves ou fatales peuvent se produire à l'extrémité du meuble.

Pour éviter les renversements:

* Installez la pointe au-dessus de la retenue fournie

* Sauf si spécifiquement conçu pour s'adapter, ne placez pas des téléviseurs ou d'autres objets lourds sur le dessus de ce produit

* Ne laissez jamais les enfants grimper ou accrocher sur les tiroirs, les portes ou les étagères

L'utilisation de la pointe sur les dispositifs de retenue ne peut que réduire, mais ne pas éliminer le risque de basculement

OPTION 1: fixation dans un goujon mural (méthode préférée)

À l'aide d'un localisateur de goujons, repérez un goujon dans le mur. Placez votre appareil contre le mur, le support de sécurité étant aligné à cet endroit.

Pour faciliter la conduite de la vis, vous pouvez percer un trou pilote de diamètre de 1/8 po (3 mm) à travers le support de sécurité dans le goujon.

Enfoncez la vis dans le support de sécurité dans le goujon mural. Serrez la vis qui n'a pas été complètement serrée à l'étape 6.

OPTION 2: attachement dans la cloison sèche

Localisez votre appareil si désiré contre un mur et marquez le mur à travers le support de sécurité, puis déplacez votre unité de côté.

Percer un trou de diamètre de 3/16 po (5 mm) dans le panneau mural. Tapoter l'ancre murale dans le trou jusqu'à ce qu'elle affleure.

Déplacez votre appareil en position et fixez le support mural à l'ancrage mural avec la vis.

Serrez la vis qui n'a pas été complètement serrée à l'étape 6.

Pour maçonnerie, béton ou autres matériaux muraux:

Pour fixer solidement le support de sécurité, consultez votre quincaillerie locale pour avoir des ancrages appropriés.

Page 22

Veillez noter:

Les trous des supports de tiroir sont fendus. Pour ajuster les façades de tiroir, desserrez les vis qui retiennent les supports du tiroir à la façade du tiroir, faites les ajustements nécessaires et resserrez les vis.

Page 23

CHARGES MAXIMALES

Ce meuble a été conçu pour supporter les charges maximales indiquées. En excédant ces limites de charge, le meuble pourrait devenir instable, s'effondrer, et/ou causer des blessures graves.

AVERTISSEMENT : Risque de blessure corporelle - ne pas placer une télévision sur ce meuble. Ce meuble n'est pas approuvé pour une utilisation avec une télévision.

Page 24

Enregistrez votre produit pour recevoir les éléments suivantes:

- * Détails sur les nouvelles tendances - un aperçu sur les nouveautés
- * Sondages - avoir une voix au sein de notre communauté
- * Offres exclusives et codes promo
- * Service de pièces de rechange rapide et facile

Pour enregistrer votre produit, visitez ameriwoodhome.com

5 Étoiles

Visitez le site Web de votre détaillant local, évaluez votre produit acheté et laissez-nous quelques commentaires !

Nous tenons à offrir un grand "Merci" à tous nos clients pour avoir pris le temps d'assembler ce produit "Ameriwood Home", et de nous donner vos commentaires précieux.

Merci